

MikroLine

- Gatot Wibowo Hamiseno
- MikroTik Certified Training Partner (2009)
- PPPPTK Yogyakarta

Wireless Advance Channel

Wireless Advance Channel

- RouterOS v6
- Atheros AR92xx
- Frekuensi 2192-2734 MHz dan 4800-6100 MHz

Wireless Advance Channel

- Perbedaan frekuensi 0,5 MHz
- Rentang channel 2,5-30 MHz, tahapan 0,5MHz

Wireless Advance Channel

- Fitur custom 'scan-list'

Scan List: ← V.5

Scan List: ↓
 ↓ ← V.6

Wireless Advance Channel

- Variasi lebar channel, keleluasaan pengaturan throughput, sinyal strength
- Peningkatan security, station tidak akan menemukan AP jika frekuensi/channel width berbeda

Wireless Advance Channel

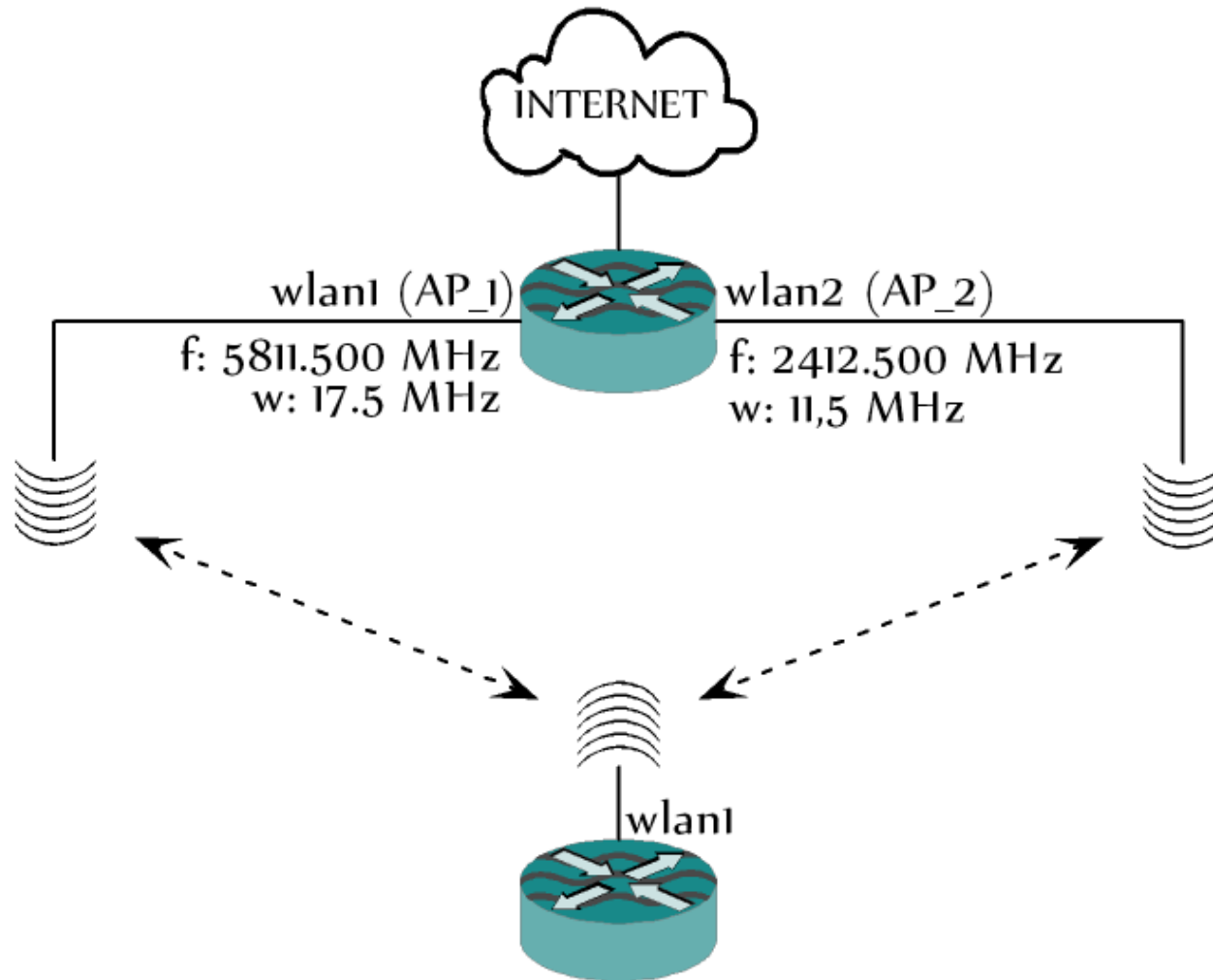

Wireless Advance Channel (AP1)

Wireless Tables

Interfaces | Nstreme Dual | Access List | Registration | Connect List | Security Profiles | Channels

+ - [Icons]

#	List	Name	Frequency (MHz)	Width (MHz)	Band	Extension Channel
0	Akses_Poin	ch_AP_1	5811.500	17.500	5GHz-A	none

Wireless Channel <ch_AP_1>

List: Akses_Poin

Name: ch_AP_1

Frequency: 5811.500

Width: 17.500

Band: 5GHz-A

Interface <wlan1>

General | Wireless | HT | WDS | Nstreme

Mode: ap bridge

Band: 2GHz-B/G

Channel Width: 20MHz

Frequency: ch_AP_1

SSID: MikroTik





Scan List: default

MikroLine -

Wireless Advance Channel(Station)

Wireless Tables

Interfaces | Nstreme Dual | Access List | Registration | Connect List | Security Profiles | Channels

#	List	Name	Frequency (MHz)	Width (MHz)	Band	Extension Channel
0	Klien	to_AP_1	5811.500	17.500	5GHz-A	none
1	Klien	to_AP_2	2412.500	11.500	2GHz-B/G	none

Wireless Channel <to_AP_1>

List: Klien

Name: to_AP_1

Frequency: 5811.500 MHz

Width: 17.500 MHz

Band: 5GHz-A

Wireless Channel <to_AP_2>

List: Klien

Name: to_AP_2

Frequency: 2412.500 MHz

Width: 11.500 MHz

Band: 2GHz-B/G

Wireless Advance Channel(Station)

Interface <Klien>

General Wireless HT WDS Nstr

Mode: station

Band: 5GHz-A

Channel Width: 20MHz

Frequency: 5180

SSID: MikroTik

Scan List: Klien

Wireless Protocol: any

Security Profile: default

Bridge Mode: enabled

Default AP Tx Rate:

Scan List: to_AP_1

Scan List: to_AP_2

Scan List: to_AP_2

to_AP_1

Wireless Advance Channel

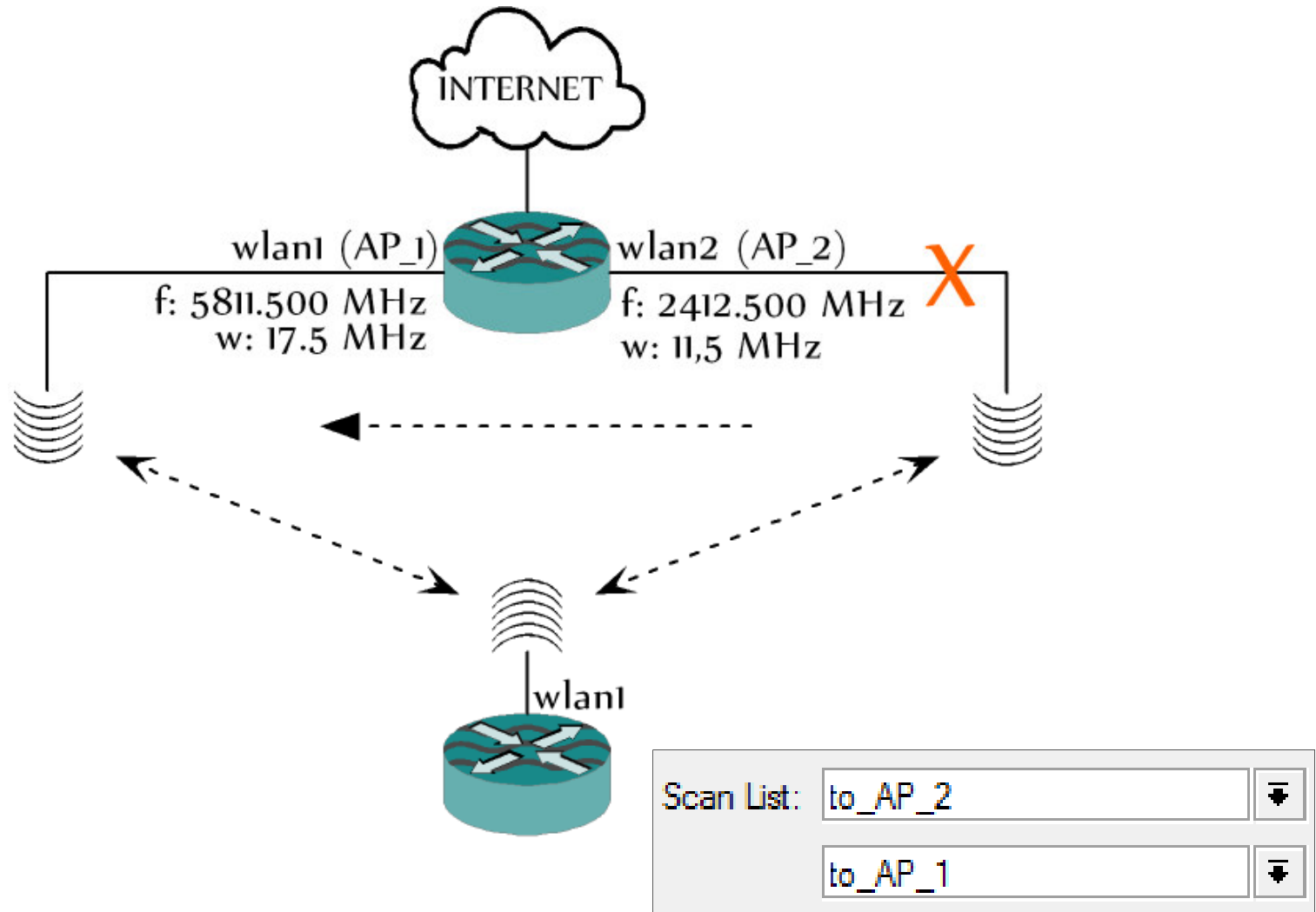

Upgrade License Advance Channel

Wireless Tables

Interfaces | Nstreme Dual | Access List | Registration | Connect List | Security Profiles | Channels

+ - [] [] [] [] []

#	List	Name	Frequency (MHz)	Width (MHz)	Band	Extension Channel
---	------	------	-----------------	-------------	------	-------------------

RouterOS WinBox Error

Couldn't add New Wireless Channel - license does not allow non-standard channel width (6)

OK

Upgrade License Advance Channel

License	
Software ID:	839Q-R8GQ
Upgradable To:	v7x
Level:	4
Features:	
Expires In:	

For already created software keys

- all keys **or** try search
- replacement key (0)
- request key from another account

If you are using a key that is not on your account, you can request it for your own use, export the key from your router, and upload it here, the key will then appear in a new virtual folder on your account, while still staying on the owners account, you will have full permissions to upgrade this key

Exported file: **No file selected.**

Or

Software ID: **839Q-R8GQ** (RouterBOARD only)

Request Key

Upgrade License Advance Channel

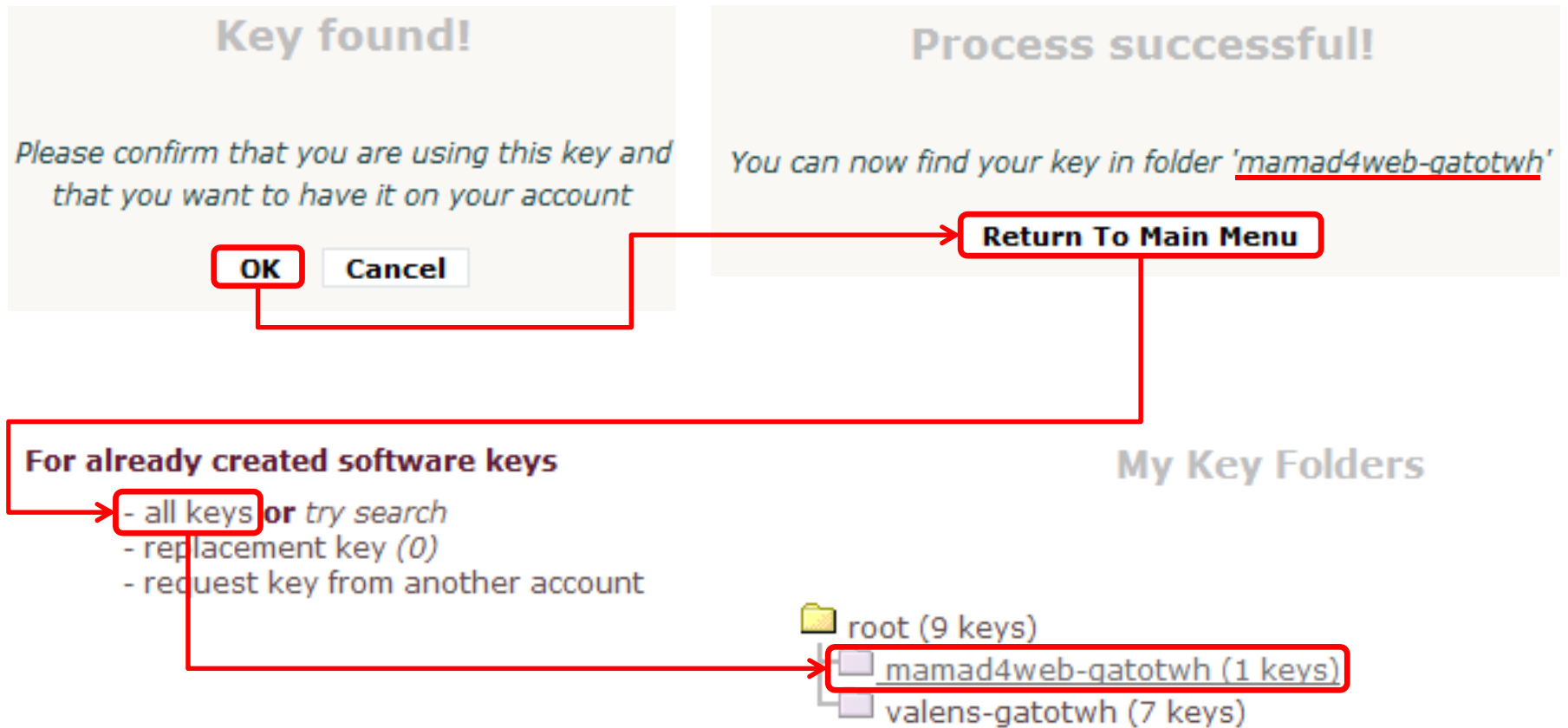

Advance Channel

My Keys

Folder: Search

Select all:

Soft ID	Key	Status	Invoice	Level	Issued	Board	Note
839Q-R8GQ	-----BEGIN MIKROTIK SOFTWARE KEY----- iKfgh4UNm1 QaMjg S1aMWz+KZPhJjNVV0ZQRcwiG+e4YZ Vfp+gHbUGHfcl+uqqXSBuG1acVz0G+RpbRCBuIPA== -----END MIKROTIK SOFTWARE KEY-----	Paid		WISP AP (Level 4)	2013-03-07	RouterBOARD	

- Already upgraded keys

Upgrade

Upgrade License Advance Channel

1 Upgrade Key 

Soft-ID: 839Q-R8GQ

Custom frequency select \$0.00

Total: \$00.00

[Previous](#) [Next](#)

2 Payment form 

Level: **WISP AP (Level 4)**

Features: **Custom frequency select**

Total Price: **\$0**

[Take Key](#)

[Previous](#)

Upgrade License Advance Channel

Issued licences

Successfully issued licenses

	Soft ID	Key	Note
<input checked="" type="checkbox"/>	839Q-R8GQ (root)	<pre>-----BEGIN MIKROTIK SOFTWARE KEY----- y8O6u3UCrXC0gmcimwuBd5hRFB02X4Nhljevkwq3tmj3 u0YREk8eVbVqATBJow91wvQLZGUBbsgtDX6e22mG4 -----END MIKROTIK SOFTWARE KEY-----</pre>	

Copy

Select All

Save Changes and Finish

Upgrade License Advance Channel

The image illustrates the steps to upgrade a license to include the 'extra-channels' feature. It consists of three windows:

- License Window (Left):** Shows the current license details: Software ID: 839Q-R8GQ, Upgradable To: v7x, Level: 4, Features: (empty), Expires In: (empty). The 'Paste Key' button is highlighted with a red box.
- License Window (Right):** Shows the same license details, but the 'Features' field now contains 'extra-channels', which is also highlighted with a red box. A red arrow points from the 'Paste Key' button in the left window to this field.
- Confirm Reboot Window:** Displays the message: "For the key change to take effect, you should reboot the router. Reboot now?". The 'Yes' button is highlighted with a red box, and a red arrow points from it to the 'extra-channels' field in the right window.

Upgrade License Advance Channel

Message

All changes saved successfully!

[Return To Main Menu](#)

Terima kasih

www.mikroline.com/mum